

# NEW CO<sub>2</sub> SENSOR WITH HIGH RESOLUTION AND FAST RESPONSE

F. Granstedt<sup>1</sup>, B. Hök<sup>2</sup>, U. Bjurman<sup>1</sup>, M. Ekström<sup>1</sup>, Y. Bäcklund<sup>1</sup>

<sup>1</sup>Department of Electronics, Mälardalen University, Västerås, Sweden

<sup>2</sup>Hök Instrument, Västerås, Sweden

**Abstract-** The most common principles for CO<sub>2</sub> sensors are only partially fulfilling the requirements of cardiovascular and respiratory applications. A new acoustic sensor principle is claimed to be favorable in several respects, such as size, resolution response time, reliability and cost. The sensor makes use of an electro acoustic element coupled to a Kundt resonator. The resonance frequency is determined by the mean molecular mass of the gas contained in the resonator, which may, in turn, be dominated by the variations of CO<sub>2</sub> concentration. A phased locked loop (PLL) oscillator provides both voltage and frequency outputs of the sensor. In this paper, a prototype design is presented, along with experimental results demonstrating that resolution, linearity and response time adequate for biomedical applications may be achieved.

**Keywords** – Acoustics, ultrasonics, carbon dioxide sensor, multigas sensing

## I. INTRODUCTION

Carbon dioxide (CO<sub>2</sub>) sensors have numerous biomedical applications, based on the fact that CO<sub>2</sub> assimilation and respiration (or combustion) are fundamental processes intimately associated with life itself.

Within the cardiovascular system, the determination of pCO<sub>2</sub> in arterial and venous blood is central to the adequate diagnostics and monitoring during any situation where the vital body functions are at stake. Within the respiratory system, CO<sub>2</sub> measurement/detection is used for monitoring during assisted ventilation, during intubation to ensure correct positioning, for assessment of end tidal CO<sub>2</sub>, and for respiratory monitoring of nonintubated patients.

In most biomedical applications, the following sensor characteristics are important (the order of priority may vary from one application to another): size, accuracy, response time, selectivity, reliability, and cost.

CO<sub>2</sub> sensors reported in the literature may be classified in three major categories, depending on whether the measuring principle makes use of phenomena within the gas, the liquid, or the solid state.

Solid state CO<sub>2</sub> sensors make use of the fact that a few solid substances selectively adsorb CO<sub>2</sub>. Combined with a Quartz Micro Balance (QMB) [1, 2] or a Surface Acoustic Wave (SAW) device [3], the minute variations in mass caused by the adsorption may be detected.

Liquid phase CO<sub>2</sub> sensors invariably makes use of the change in pH coinciding with CO<sub>2</sub> concentration due to the formation of carbonic acid, and its hydrolysis taking place in aqueous solutions:

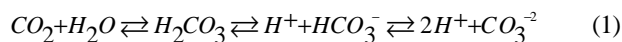

pH may be measured with glass electrodes [4, 5], Ion

Sensitive Field Effect Transistors (ISFET) [6] or by colorimetry [7].

The dominant gas phase principle is Nondispersive Infrared Spectroscopy (NDIR) [8], based on specific absorption at the 4.23 μm band. Most sensors use dual wavelength transmission measurements with an IR source, a filter, and a pyroelectric detector.

Recently, we have suggested [9-11] an acoustic sensor principle, measuring variations of the sound velocity in a resonating cavity at constant temperature. The resonance frequency variation Δf will ideally be determined by the CO<sub>2</sub> concentration X<sub>CO<sub>2</sub></sub> according to

$$\frac{\Delta f}{f} = \frac{-(M_{\text{CO}_2} - M_0) X_{\text{CO}_2}}{2M_0} \quad (2)$$

where M<sub>CO<sub>2</sub></sub> is the molecular mass of CO<sub>2</sub>, and M<sub>0</sub> is the average molecular mass of air.

A comparison of the various sensor principles with respect to the list of important characteristics is made in Table 1. The scaling properties are favorable for all principles except NDIR. The relatively weak absorption is a limiting factor for the degree of miniaturization of the measuring cell. This is also a fundamental limitation for either the accuracy or response time. The accuracy of the pH-based methods is limited [12], whereas all methods except possibly the NDIR have capability of fast response. The acoustic principle is basically nonselective, limiting its usefulness to situations where the gas composition is known, and where the variability of the mean molecular mass correlates with CO<sub>2</sub> concentration (after compensation for H<sub>2</sub>O variations). Such conditions prevail when a subject is breathing in a normal atmosphere. The reliability of the solid and liquid state sensor principles is problematic, due to the fact that these sensors may be ‘poisoned’ by other substances. The cost issue is governed by the compatibility to high volume production processes.

	Solid	Liquid pH electrode	Liquid colorimetry	Gas NDIR	Gas acoustic
Size	+	+	+	-	+
Accuracy	+	-	-	(+)	+
Response time	+	+	+	(-)	+
Selectivity	+	+	+	+	-
Reliability	-	-	-	+	+
Cost	+	-	+	-	+

Table 1. Comparison of known CO<sub>2</sub> sensor principles with respect to characteristics of importance in biomedical applications (plus sign: favorable, minus sign: less favorable characteristics)

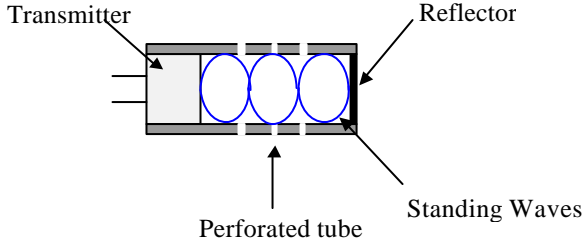

Fig. 1. The CO<sub>2</sub> sensor setup.

## II. SENSOR DESIGN

The basic mechanical design of our sensor prototype is shown in Fig. 1. It consists of a commercially available ultrasonic transmitter, operating at 40 kHz (SQ-40-T/R/10B, Low Power Radio Solutions Ltd, Oxon, U.K.) coupled with an acoustic resonator according to Kundt, i.e. basically a piece of tubing with a length corresponding to  $n * \lambda/2$ ,  $\lambda$  being the wavelength ( $\lambda=8.5$  mm at 40 kHz), and  $n$  an integer. Fig. 2 shows the electrical impedance of the sensor shown in Fig. 1 as a function of frequency [10]. The most prominent peak at 40.8 kHz represents the equivalent parallel resonance, whereas the peak at 39 kHz is a result of standing waves within the resonator, and is also (approximately) coincident with an impedance minimum of the transmitter itself. Also shown in Fig. 2 is that the 39 kHz peak will shift towards lower frequency, with increasing CO<sub>2</sub> concentration, as mentioned above.

The frequency shift observed in Fig. 2 is used for controlling the output frequency of an oscillating circuit. The circuit must be capable of locking at the 39 kHz peak, without locking at the nearby frequency peak at 40.8 kHz. Such circuits may be implemented using phase locked loops (PLL), consisting of a voltage controlled oscillator (VCO), a phase comparator and a lowpass filter. The phase difference between the input and the VCO signals is driven to a nearly constant value by continuous adjustments of the VCO frequency.

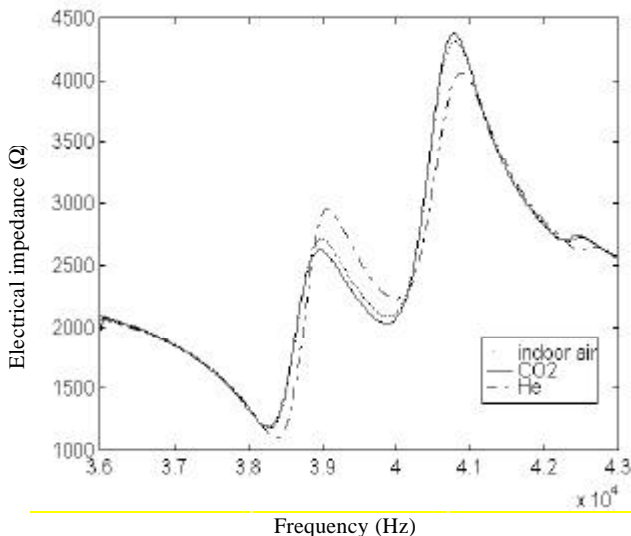

Fig. 2. Electrical impedance as a function of frequency for the sensor in normal indoor air and addition of 0.7% CO<sub>2</sub> and He, respectively.

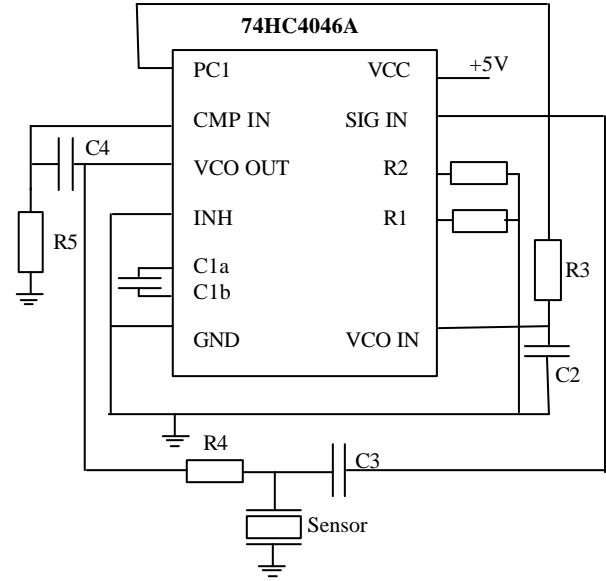

Fig. 3. The PLL setup.

The implementation of an oscillator circuit is depicted in Fig. 3. A low cost standard CMOS PLL (74HC4046A) was selected, with five resistors R1-R5 and four capacitors C1-C5 as additional components. The locking frequency range is determined by R1, R2 and C1. R4 and C3 provide the necessary 90° phase difference for the phase comparator, and R3, C2 define the lowpass filter. The circuit provides both a frequency output, at the VCO OUT terminal, and a voltage output from the lowpass filter.

## III. METHOD

To determine the relationship between relative CO<sub>2</sub> concentration and frequency shift, the sensor and the electronic interface was mounted inside a gas tight chamber.

A total of one liter CO<sub>2</sub> was administrated into the fourteen-liter chamber, which was kept at approximately 22 °C, and 30 % relative humidity. The gas was administrated twenty times and the relative CO<sub>2</sub> concentration was increased by 0.3 % each time. A small fan was mounted inside the chamber to ensure a proper gas mix.

The sensor was mounted inside a small tube to measure the total response time for the electronic device and the sensor. The concentration inside the tube was quickly changed from a CO<sub>2</sub> concentration of 3% to normal indoor air. The length of the tube was 6.7 cm and the volume 30 cm<sup>3</sup>.

## IV. RESULTS

It is possible to implement an electro acoustic sensor using a low cost standard CMOS PLL locking at a small resonance peak closely located to a bigger peak. Undesired locking to the 40.8 kHz peak was prevented by adjusting the capture range with proper dimensioning of R1, R2, C1.

Fig. 4 shows that the output frequency of the sensor has a nearly linear relationship to CO<sub>2</sub> concentration in the range 0 - 7.1%, with a sensitivity factor of -31 Hz/%CO<sub>2</sub>. The result

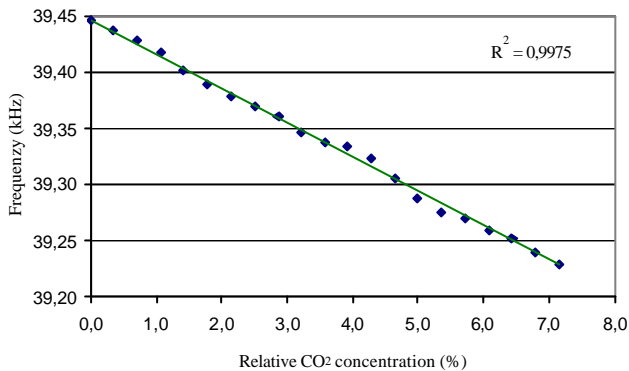

Fig. 4. Output frequency as a function of CO<sub>2</sub> concentration.

also implies that the phase change in the ultrasonic device is linear. The correlation factor ( $R^2$ ) for the relationship between the output frequency and CO<sub>2</sub> concentration is 0.9975.

The total response time for the whole system as determined by a step response was about 200 ms, as shown in Fig. 5. The lowpass filter R3C2, having a time constant of 1 ms, makes a marginal contribution.

## V. DISCUSSION

In this paper, we have demonstrated that acoustic CO<sub>2</sub> sensors may be implemented using low cost materials and components. Using a PLL, frequency and voltage output signals are generated which can easily be made compatible with most systems for patient diagnostics or monitoring. The prototype design exhibits very favorable characteristics, although it is far from optimized.

The output signal of the prototype is highly linear, with a dynamic range exceeding 60 dB. The actual linearity may in fact be further improved, if the gas inside the measuring chamber was allowed to reach equilibrium for each measuring point. The observed sensitivity of 31 Hz/%CO<sub>2</sub> is considerably smaller than predicted from eq. (2). This may be explained, at least qualitatively, by coupling to the resonant properties of the electroacoustic element itself.

In a previous paper [9], ppm resolution was demonstrated in an acoustic sensor based on an identical basic principle, using a transmitter/receiver pair acting across a Kundt resonator instead of the single element used in this investigation. When optimized, the present design is likely to match this resolution, making environmental monitoring and control a feasible application area.

The response time reported in this paper is possibly limited by diffusion. Assuming a diffusion constant  $D=10^5$  m<sup>2</sup>/sec [13], the diffusion length corresponding to a time constant  $\tau=300$  msec is  $L=(D\tau)^{1/2}=1$  mm, i.e. roughly corresponding to the cell dimensions. Another possible limiting factor of the experiment is, of course, the speed with which the step change is generated. Regardless of the limiting cause, the reported speed of response is adequate for most medical applications. In Table 1, the acoustic sensor principle is claimed to be favorable in all respects, except selectivity. This limitation must be considered when other heavy molecules may be present, e.g. anesthetic gases. Sensitivity to

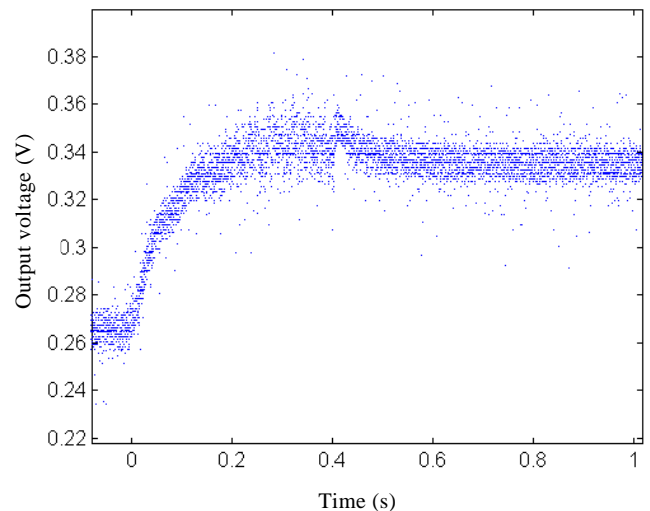

Fig. 5. The total response time for the whole system.

H<sub>2</sub>O and other polar molecules may be effectively reduced using a moisture trap consisting of a strongly adsorbing material.

The capability of the new sensor in terms of accuracy and response time has been demonstrated, whereas the potential degree of miniaturization at this point can only be discussed in terms of basic properties. If the prototype dimensions would be scaled down, the operating frequency would linearly increase. A fundamental upper limit of the operating frequency is set by acoustic absorption, which will become dominant in the low MHz range. Still, there is a distinct possibility of scaling down the physical dimensions by more than an order of magnitude compared to the prototype. This will open up the possibility of intravascular measurements using catheter tip, guidewire, or hypodermic needle assemblies. Miniaturization will also be important in respiratory applications, especially for monitoring of nonintubated patients.

Present CO<sub>2</sub> sensors are relatively expensive devices, which is a limiting factor in medical applications. Ideally, sensors for the cardiovascular or respiratory tracts should be sterile or disinfected disposables to minimize the risk for the spread of harmful microorganisms. To obtain this goal, the costs for material, components, and labor must be minimal. A possible solution, which seems to be compatible with the basic acoustic sensor concept as described, would be an integrated microsystem based on silicon technology.

## V. CONCLUSION

We have demonstrated the feasibility of acoustic CO<sub>2</sub> sensors and verified that this type of sensor exhibits favorable characteristics in terms of sensitivity, linearity, resolution, and response time. Further progress concerning miniaturization and production cost, can be expected in the near future.

## ACKNOWLEDGMENTS

Financial support from Västmanlands FoU-Råd, NUTEK, Teknikbrotstiftelsen and KK-Stiftelsen is gratefully acknowledged.

## REFERENCES

- [1] R. Zhou, S. Vaihinger, K.E. Geckeler, W. Göpel "Reliable CO<sub>2</sub> sensors with silicon-based polymers on quartz microbalance transducers", *Sensors and Actuators B* 18-19 (1994) 415-420.
- [2] MT Gomes, AC Duarte, JP Oliveira Detection of CO<sub>2</sub> using a quartz crystal microbalance, *Sensors and Actuators B* 26-27 (1995) 191-194.
- [3] S.W. Wenzel, R. M. White, "Flexural plate-wave gravimetric chemical sensor", *Sensors and Actuators A* 21-A23 (1990) 700-703.
- [4] R.W. Stowe, R.F. Baer, B. F. Randall, "Rapid measurement of the tension of carbon dioxide in blood", *Arch. Phys. Med.* 38 (1957) 646-650.
- [5] J.W. Severinghaus, A.F. Bradley, "Electrodes for blood pO<sub>2</sub> and pCO<sub>2</sub> determination," *J. Appl. Physiol.* 13 (1958) 515-520.
- [6] P. Bergveld, "Development of an ion-sensitive solid-state device for neurophysiological measurements", *IEEE Trans. Biomed. Eng.* 19 (1970) 70-71.
- [7] A. Gedeon, P. Krill, C. Mebius "A new colorimetric breath indicator, *Anaesthesia* 1994 vol 49 pp 798-803.
- [8] RJ Solomon, A reliable, accurate CO<sub>2</sub> analyzer for medical use, *Hewlett Packard Journal*, vol 32 (9), 1981, 2-21.
- [9] B. Hök, M. Tallfors, G. Sandberg, and A. Blücker, "Acoustic Gas Sensor with ppm Resolution," presented at *EuroSensors XIII*, The Hague The Netherlands, 1999.
- [10] B. Hök, M. Tallfors, G. Sandberg, and A. Blücker, "A new sensor for indoor air quality control," presented at *EuroSensors XII*, Southampton U.K., 1998.
- [11] F. Granstedt, M. Folke, Y. Bäcklund, and B. Hök, "Gas Sensor with Electroacoustically Coupled Resonator," presented at *EuroSensors XIV*, Copenhagen Denmark, 2000.
- [12] S.S. Kuan, G.G. Guilbault "Ion-selective electrodes and biosensors based on ISEs", Chapter 9, pp 135-152 in "Biosensors, Fundamentals and Applications", Eds. A.P.F. Turner, I. Karube, G.S. Wilson, Oxford University Press, Oxford, 1987.
- [13] R.J. Seager "Fluid Mechanics", Chapter 2, p 3-33, *Handbook of Physics*, 2<sup>nd</sup> Ed., Editors E.U. Condon, H. Odishaw, Mc Graw-Hill, New York, 1967.